



VARIABLE SPEED PACKAGE SYSTEM INSTALLATION, OPERATION & MAINTENANCE MANUAL



SENCILLO SYSTEMS, INC.
966 Argyle Rd, Warrington, Pa 18976

www.SencilloSystems.com

Tel: (610) 340-2848

Fax: (610) 510-5242

Table of Contents

Introduction and Safety	3
Introduction	3
Purpose of this Manual.....	3
User Safety	3
General Safety Rules	3
Safety Equipment	4
Electrical Connections.....	4
Precautions	4
Product Warranty.....	4
Delivery and Storage	6
Inspect the Delivery	6
Inspect the Package	6
Inspect the Unit.....	6
Transportation Guidelines	6
Lifting Methods	6
Storage Guidelines	6
Storage Location.....	6
Long Term Storage.....	6
Product Description	7
Description	7
Intended Applications	7
Nameplate Information	7
Nameplate Data	7
Installation	9
Field Connections.....	9
Drawings (General Arrangement/Electrical).....	9
Electrical Precautions	9
Ground Connections.....	9
Long Term Storage.....	9

Foundation Requirements..... **10**
 Requirements.....10
 Level the Unit on a Concrete Foundation10
Piping Checklist **10**
Start-Up and Operation **11**
 Preparation for Start-Up11
 Precautions11
 Prestart-Up Checklist.....11
 Site Voltage11
 Suction Water11
 Start the System.....12
 Testing the System12
 System Operating Screens.....13
 BOP Operation27

Introduction and Safety

Introduction

Purpose of this Manual

The Purpose of this Manual is to provide information for:

- Installation
- Operation
- Maintenance

CAUTION:

Read this manual in its entirety before installing and using the product. Improper use of the product can cause personal injury or death, damage to property, and may void the warranty.

WARNING:

- The operator must be aware of safety precautions to prevent physical injury.
- Any pressurized device can explode or discharge, if contents is over pressurized. Take all necessary measures to avoid over pressurization.
- Operating, installing, or maintaining the unit, in any way that is not covered in this manual, could cause death, serious injury, or damage to the system. This includes any modifications to the equipment, or use of parts not provided by Sencillo Systems, Inc. [™] Please contact Sencillo Systems, Inc. [™], for clarification before proceeding.
- This manual clearly identifies accepted methods for disassembling units and must be adhered to at all times. Trapped liquid can rapidly expand and result in a violent explosion and injury. Never apply heat to impellers, or their retaining devices, to aid in their removal.
- Do not change the service application without the approval of Sencillo Systems, Inc. [™].

User Safety

General Safety Rules

These Safety Rules apply:

- Always keep the work area clean.
- Avoid all electrical dangers. Pay attention to the risks of electric shock or arc flash hazards.
- Always keep in mind the risk of electrical accidents and burn injuries.

Safety Equipment

Use necessary safety equipment in accordance with regulations.

- Safety Goggles
- Protective Shoes
- Hearing Protection

Electrical Connections

Electrical connections must be made by a certified electrician, in compliance with all international, national, state, and local regulations. For more information about requirements, see the electrical connections section of this manual.

Precautions

Observe these safety precautions when you work with or are in close proximity to the system:

- Never work alone.
- Always wear protective clothing and hand protection.
- Stay clear of suspended loads.
- Always lift the system by its lifting device.
- Beware of the risk of a sudden start, if the product is used with an automatic pressure control.
- Do not exceed the maximum working pressure of the pump.
- Do not open any vent or drain valve, or remove any plugs while the system is pressurized. Make sure the pump is isolated from the system and pressure is relieved before you disassemble the pump, remove plugs, or disconnect piping.
- Never operate a pump without a properly installed coupling guard.

Product Warranty

Coverage

Sencillo Systems, Inc. TM undertakes to remedy faults in products under these conditions:

- The faults are due to defects in design, materials, or workmanship.
- The faults are reported to Sencillo Systems, Inc. TM in writing and within the warranty period.
- The product is used only under the conditions described in this manual.
- All service and repair work is done by Sencillo Systems, Inc. TM authorized personnel.

Limitations

The warranty does not cover faults caused by these conditions:

- Deficient maintenance.
- Improper installation.
- Modifications, changes to the product, or installations made without the written approval of Sencillo Systems, Inc. TM.
- Incorrectly executed repair work.
- Normal wear and tear.

Sencillo Systems, Inc. [™] assumes no liability for these conditions:

- Bodily injuries.
- Material damages.
- Economic losses.

Warranty Claim

Sencillo Systems, Inc. [™] products are high quality products with expected reliable operation and long life. However, should the need arise for a warranty claim, please contact Sencillo Systems, Inc. [™] or your authorized Representative.

Delivery and Storage

Inspect the Delivery

Inspect the Package

- Inspect the package for damaged or missing items immediately upon delivery.
- Note any missing or damaged items on the freight bill.
- Notify the shipping company immediately upon inspection of damaged or missing items.

Inspect the Unit

- Remove packing material from the product.
- Inspect the system for damaged or missing items. (If applicable, unfasten the product by removing any screws, bolts, or straps to properly inspect the entire system).
- Contact your Sencillo Systems, Inc.™ Representative if anything does not look correct.

Transportation Guidelines

Lifting Methods

- Assembled units are heavy. Failure to properly lift and support the equipment can result in serious physical injury and/or equipment damage.
- Use proper lifting methods and wear steel-toed shoes at all times.
- Observe Tip-over hazard precautions.
- Do not attach ropes to the control panel.

Storage Guidelines

Storage Location

- The unit must be stored in a covered and dry location that is free from: heat, dirt, and water.
- Protect HMI from heat, moisture, and anything that can scratch the surface.

Long Term Storage

In addition to the normal storage guidelines above, you will also need to:

- Drain system of any water.
- Protect unit from: heat, dirt, and water.
- Cover controller with tarp.
- Rotate the pump shaft, by hand, several times, once a month.

Product Description

General Description

Description

Provide a pre-engineering VFD (Variable Frequency Drive) packaged booster system:

- UL508A listed Controller
- Lead Free components
- Energy efficient

Intended Application

The Packaged Booster System is intended for the following application:

- Commercial Building.
- Industrial Plants.
- Municipal Water Supply
- Resorts & Vacation Facilities
- Government Facilities

Nameplate Information

Nameplate Data

All systems have a nameplate that provides important information about the unit. The nameplate can be found inside the door, or can be accessed using the HMI screen.

Please have the following information available before contacting your authorized Sencillo Systems, Inc.™ Representative:

- Project Name.
- Project Number.
- Serial Number.
- Part Number of required items.



Sencillo Systems
966 Argyle Rd.
Warrington, Pa 18976

Project Name:

Project Name:

Serial No:

Voltage:

System Capacity: xxx GPM @ xxx TDH

Pump(s) (GPM):

Motor(s) (HP):

Project No:

UL File No:

Voltage:

Largest Motor:

Full Load Amps:

MOP:

Enclosure Type 1

Short Circuit Current Rating: 5kA

Use Copper Wire Only:

100Amp or more use 75° Celsius Wire

Less than 100Amp, use 60° Celsius Wire

Torque Terminals:

Installation

Field Connections

Drawings (General Arrangement / Electrical)

Actual equipment models installed are system specific. Refer to specific manufacturer Operation and Maintenance manuals for details unique to each component.

Review the General Arrangement and Electrical drawings before you install the system.

Electrical Precautions

Warning: Electrical Shock Hazard. The electrical supply must match the control panel nameplate specifications. Incorrect voltage can cause a fire, which damages the electrical components, and voids the warranty. Failure to follow these instructions may result in serious personal injury, death, or property damage.

Note: Electrical connections must be made by a certified electrician in compliance with all international, national, state, and local regulations/codes.

Warning:

- Only use fasteners of the proper size and material.
- Replace all corroded fasteners.
- Be sure that all fasteners are properly tightened and that none are missing.

Ground Connection

- Electrical Shock Hazard. Conduit grounds are not adequate. You must attach a separate ground wire to the earth (ground) lug provided in the enclosure in order to avoid a potential safety hazard. Failure to follow these instructions can result in serious personal injury, death, or property damage.
- A grounding terminal is provided for a dedicated ground wire connection. You must follow all provisions of the National Electrical Code and Local Codes.

Foundation Requirements

Warning: Electrical Shock Hazard. An electrical conduit installed below the surface may require a corrosion-resistant protective coating in order to prevent conduit corrosion and electrical shock. Failure to follow these instructions can result in serious personal injury, death, or property damage.

Requirements

- The foundation must be able to absorb any type of vibration, and form a permanent, rigid support for the system.
- The foundation must weigh at least 2 ½ times the weight of the pumps' unit.
- Provide a flat and substantial concrete foundation in order to prevent strain and distortion when you tighten the foundation bolt.
- Tie the concrete pad in with the finished floor.

Level the Unit on a Concrete Foundation

- Place the system on a level concrete foundation.
- You may shim, if necessary, at each anchor bolt location.

Piping Checklist

- Be sure that the Suction and Discharge pipes are supported independently by use of pipe hangers near the unit.
- Be sure that the Suction and Discharge piping are not forced into position.
- Be sure that the flange bolts are adequately torqued.
Be sure that fittings are not loose.

Start-Up and Operation

Preparation for Start-Up

Warning: Electrical shock hazard. Always disconnect and lock out the power before you service the system.

- Failure to follow these precautions before you start the unit will lead to serious personal injury and equipment failure.
- Do not operate the pump with the suction or discharge valves closed.
- Never operate the pump(s) without the coupling guard installed (if applicable).
- Always turn off circuit breaker, prior to performing any maintenance tasks to drives. Failure to do so can result in serious personal injury.

Precautions

- Flush and clean the system thoroughly. Remove all dirt or debris in the pipe system in order to prevent failure at initial start-up.
- Verify settings on controller match the site conditions.

Prestart-Up Checklist

- Inspect the pumps and piping system for any visible damage.
- Check for loose fittings (flanges, electrical, tubing, etc.).
- Bleed sensing lines.
- Verify the incoming suction pressure meets or exceeds the design pressure.
- Check that the rotation of the pump(s) is correct.

Site Voltage

- Check all power connections and secure all wires as needed.
- Verify system data compared to actual site data.
- Use a volt meter to check the voltage on the incoming power terminals at the disconnect switch.
- Compare the voltage data to the Controller Nameplate.

Suction Water

- Open all supply, discharge and pump isolation valves.
- Close the bypass valve (if applicable).
- Inspect all pipe/tube fittings for leaks.
- Verify the incoming suction pressure meets or exceeds the design pressure. If suction pressure does not meet or exceed the design pressure, contact the contractor to correct the problem.

Start the System

- Close the disconnect in order to apply power to the system.
- Set/Confirm all setting on the HMI.
- Check the motors for freedom of rotation and proper direction by “bumping” each pump.
- “Bumping” is completed by placing the pump in “Hand” position, then “Off” position.
(Repeat for each pump)

Testing the System

- Observe the pressure for normal operation.
- Press the Alternate Lead/Lag button and observe the operation of each pump.
- Close the running faucet. If there is no demand of water, the system will shut down.
- Open a faucet and force a demand on the system, and observe the restart of the pump(s).

Congratulations, Start-up is complete!!!

Operating Screens

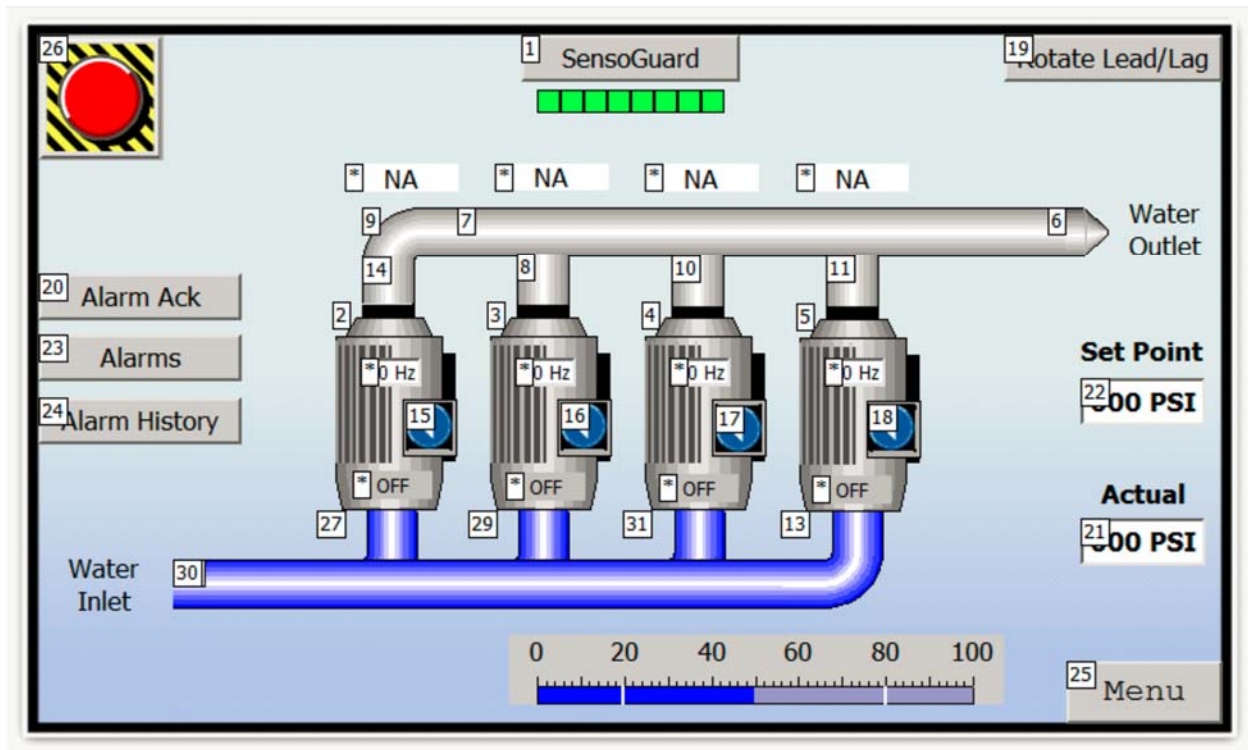

All Sencillo Systems variable speed packaged pump systems with the color touch screen incorporate the following basic operating functions regardless of size, type or horsepower:

Pump Status – each pump status can be identified by its nomenclature (Hand, Off, Auto) on the pump icon. When a pump is running, the pump will be displayed in a green color. When a pump has been placed into the “Off” position or is not running, it will be displayed in a gray color. The status of any pump can be changed by pressing the pump icon, then selecting the virtual H-O-A button.

Flow Animation – the color of the piping will change from a gray color to a blue color to provide a visual indication of which pump is running.

Lead/Lag Pumps – one pump operates continuously at various speeds to maintain the system set-point pressure. When the building demand exceeds the Lead-Lag operating range of the lead pump, the second pump (Lag 1) is automatically started. On a three (3) pump system, the third pump (Lag 2) is brought on the same way when the demand exceeds the Lead-Lag operating point of the Lag 1 pump, and so on for a four (4) pump system. The sequence of operation acts in reverse when there is a decrease in demand.

Sequencing of Pumps – starting and stopping of the pump(s) are achieved by a combination of lead-lag & system set-point. The lead-lag is pre-determined based on factory tests and pump characteristics. A pre-determined minimum/maximum hertz set-point along with a minimum run hertz setting will bring the lag pump(s) on if the lead pump is operating and not maintaining system set-point pressure.

Pump Speed – the pumps(s) RPM are controlled by a Variable Frequency Drive (VFD) connected directly to each individual pump motor. A signal from the discharge pressure transducer is constantly being compared to the system set-point on the HMI. The pump logic controller (PLC) then sends a signal to the VFD to either speed up or slow-down in order to meet or maintain the system set-point pressure.

Alarms – the pump system comes standard with the following alarms/warnings:

- Low suction pressure warning
- Low suction pressure alarm
- High system pressure warning
- High system pressure alarm
- Pump failure
- Pressure transducer failure

Pump Fault – if a motor were to fail or a drive fault, the faulted pump will be placed into the “Off” position, and the horn will sound. The horn can be silenced via the “Alarm Ack” button on the home screen. The next available pump in sequence will start automatically. The PLC is programmed to skip the faulted pump during normal operating conditions until the fault has been resolved.

High System Alarm – a high system pressure alarm logic has been programmed into the PLC and is included with every system to protect the pumps from over pressurizing the building. If the operating pressure exceeds the system set-point by a predetermined value, the pumps will shut-down. The horn can be silenced via the “Alarm Ack” button on the home screen. Once the operating pressure drops below the system set-point the pumps will automatically restart to maintain the system set-point pressure.

No-Flow Shutdown – during low or slow periods of demand, the lead pump in operation will reduce speed to determine if pressure in the building will be reduced. If the pressure is reduced by 3 PSI, during this slowdown period, the drive will speed back up to maintain system set-point. If the pressure does not drop below the 3 PSI, during the slowdown period, the drives will begin to slow down until they finally turn off. Once the system set-point pressure drops below 5 PSI from the system set-point, the pumps will turn back on to maintain set-point.

Rotate Lead/Lag - at any point during operation, the user has the ability to rotate the lead pump by pressing the “Rotate Lead/Lag” button.

Pump Alternation – the lead pump is alternated if the system is shutdown on no-flow or if the lead pump has been continuously running for more than eight (8) hours.

System Set-Point– the system set-point can be changed by pressing the current set-point value and entering a new set-point.

Power Failure – in the event that power is lost to the system, all settings are saved in active memory. Upon restoration of building power, the controller will reinitiate and restore the system pressure to the pressure that was logged in the system when power was lost.



SIMPLE. That is what the word "Sencillo™" (pronounced SEN'-see-oh) means in the Spanish language. Everything we do at Sencillo™ is done with that in mind. When you select a Sencillo™ system, we want every aspect of doing business with us to be just that - simple. The pumps and motors are simple to replace; the controller is simple to understand and operate. The logic for operating pumps doesn't need to be complicated to operate correctly. We do the hard work behind the scenes, so your job of selecting, purchasing, running and maintaining a Sencillo™ system can be wrapped up in one word - SIMPLE.

Welcome!

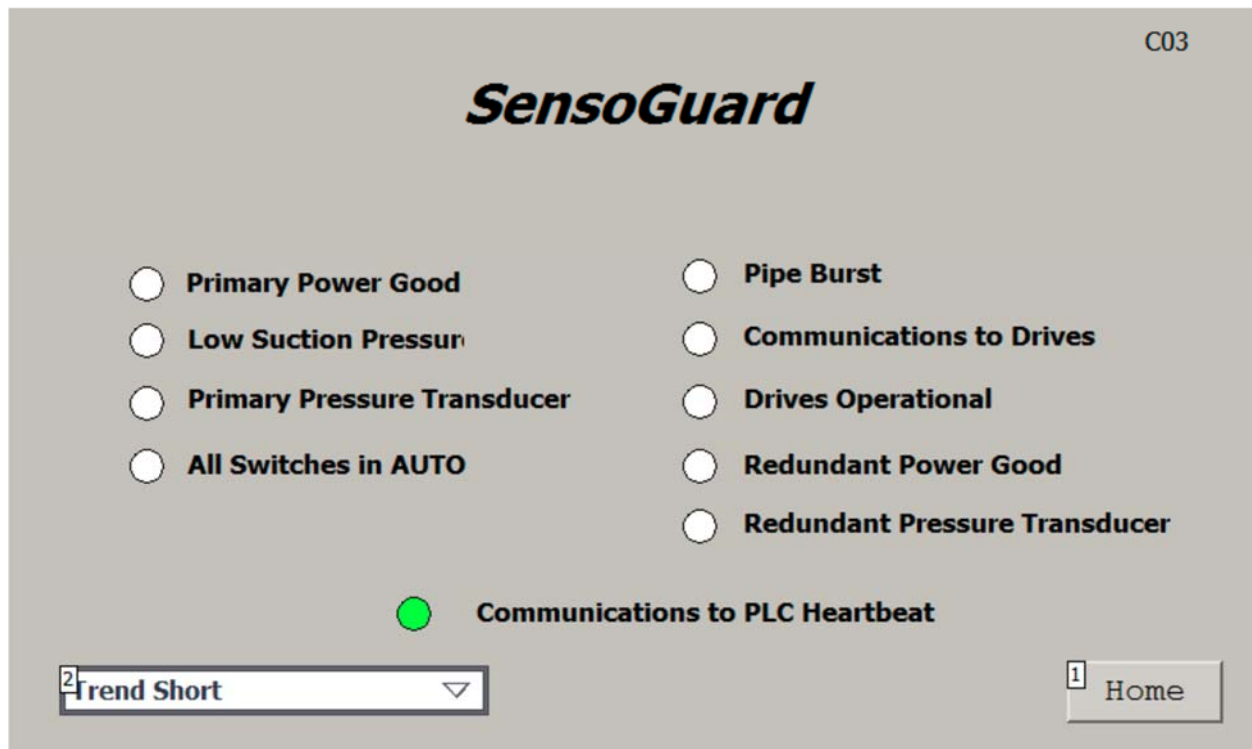

The **Sensoguard™** system is a proactive controller monitoring system built into the control scheme. Sensoguard™ constantly checks status on all major components on the Sencillo™ controller, and reports general system health. It gives immediate feedback on any trouble spots or failures, to quickly and effectively warn the owner of potential issues. Also built in are a layered backup logic schemes, designed to keep your pump system in operation, and water pressure in the building, even in case of a major component failure.

Primary Power Good – the system is checking status of the 24VDC in the Primary Power supply.

Low Suction Pressure – a low suction pressure switch is included with every system to protect the pumps from a loss of suction pressure. If the supply (Tank/City) pressure falls below 10 PSI, the Low Suction Pressure Alarm will be activated and the horn will sound and the pumps will be prevented from running. The horn can be silenced via the “Alarm Ack” button on the home screen. Once the supply pressure has been re-established about the 10 PSI, then the pumps will automatically restart to maintain the system set-point pressure.

Pressure Transducer Failure – in the event that the pressure transducer were to fail, all of the pumps except for the lead pump will be placed into the “Off” position. The lead pump will be placed into the “Hand” position and will run at a predetermined speed until the transducer has been replaced. The operator can adjust the speed to maintain system pressure.

All Switches in Auto – There will be a yellow light that will give the operator a proactive alert that one of the pumps is not in the “Auto” position.

Pipe Burst - in the event that all of the pumps are running at full speed (60 Hertz) for a predetermined amount of time, and the system pressure is not being satisfied, all of the pumps will be placed into the “Off” position.

Communications to Drives – the system is checking communication between the PLC and the Drives.

Drives Operational – is a verification that the drives are operational.

Redundant Power Good (Optional) – the system is checking status of the 24VDC for the Secondary Power supply.

Redundant Pressure Transducer Failure (Optional) – in the event that the main pressure transducer were to fail, the system will start to read the value of the redundant pressure transducer. In the event that the redundant transducer were also to fail, all of the pumps except for the lead pump will be placed into the “Off” position. The lead pump will be placed into the “Hand” position and will run at a predetermined speed until the transducer has been replaced. The operator can adjust the speed to maintain system pressure.

Communication to PLC heartbeat – the system is checking communication between the PLC and the HMI.

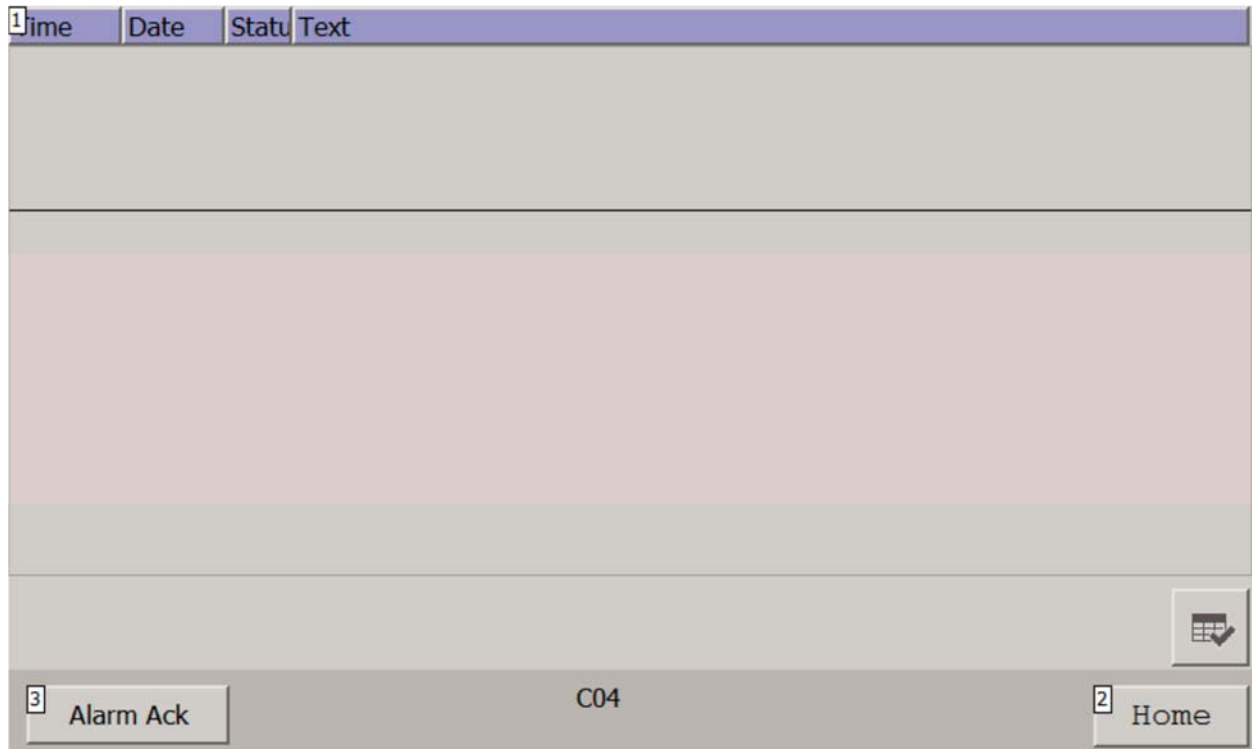

Alarms – the pump system comes standard with the following alarms/warnings:

- Low suction pressure warning
- Low suction pressure alarm
- High system pressure warning
- High system pressure alarm
- Pump failure
- Pressure transducer failure

1	No.	Time	Date	Statu	Text	Acknov
<div style="text-align: right; margin-top: 10px;">  </div>						
C05						<div style="text-align: right;"> 2 Home </div>

Alarm Log – the controller scroll through the last 50 warnings/alarms.

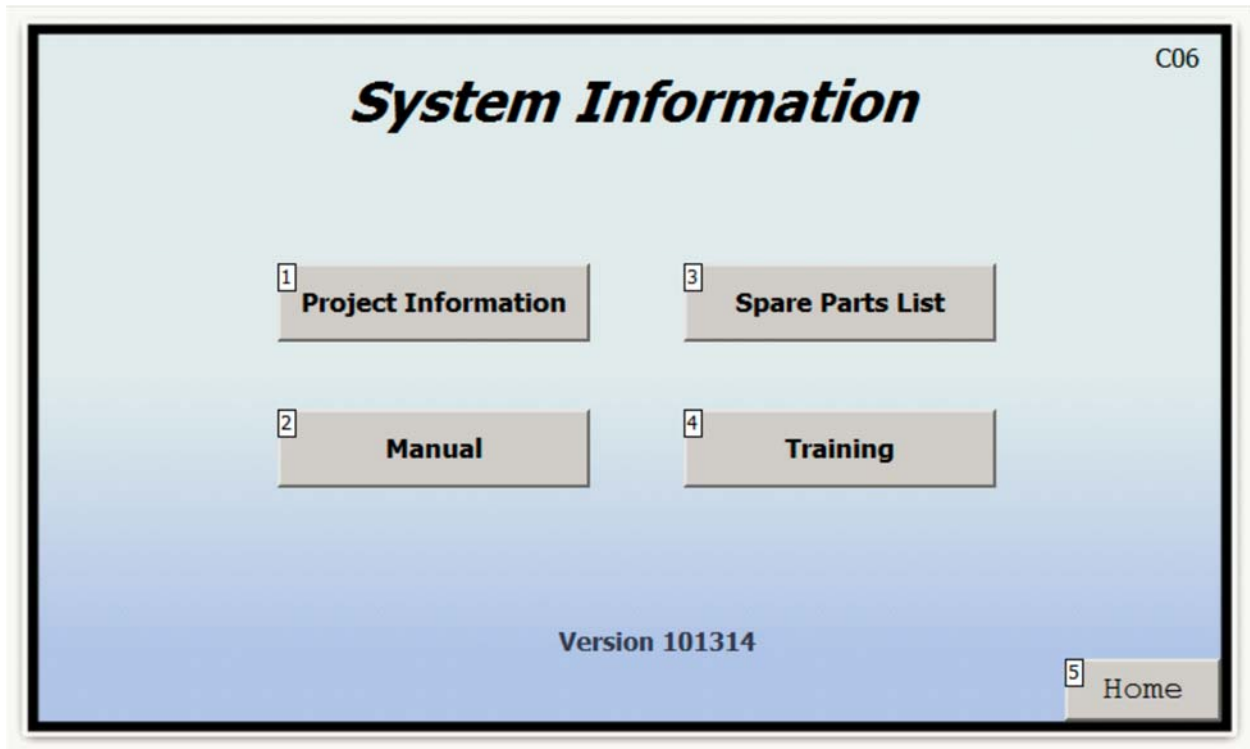

Project Information – system information is stored under the Project Information button which include:

- Project Name
- Project Number
- Project Location
- Serial Number
- Model Number

Spare Parts List – all of the systems major components are listed under the Spare Parts List button which include the follow:

- HMI
- PLC
- Drives
- Power Supply
- Pressure Transducer
- Low Suction Switch

Manual – a copy of this document can be located on the HMI under the Manual Button.



Project Information – system information is stored under the Project Information button which include:

- Project Name
- Project Number
- Project Location
- Serial Number
- Model Number

C08

Spare Parts List

Qty	Description	Part No
1	Touchscreen	0502-003-720
1	PLC	0502-054-720
3	Drives	0503-041-460
1	Pump #1	Call
1	Pump #2	Call
1	Pump #3	Call
-	Pump #4	N/A
1	Power Supply	0502-080-720
1	Pressure Transducer	0310-019-100
1	Low Suction Switch	0301-001-500

1 Back 2 Home

Spare Parts List – all of the systems major components are listed under the Spare Parts List button which include the follow:

- HMI
- PLC
- Drives
- Pumps
- Power Supply
- Pressure Transducer
- Low Suction Switch



Required Maintenance – once a year this screen will appear to give the end user a preventative maintenance reminder to call their local Sencillo Systems distributor and have their system check out. The service call will include the following:

- View/Record the Alarm History
- Take voltage readings of each pump
- Take amperage reading of each pump
- Calibrate the Pressure Transducer (if necessary)
- Provide written report to end user with any maintenance suggestions

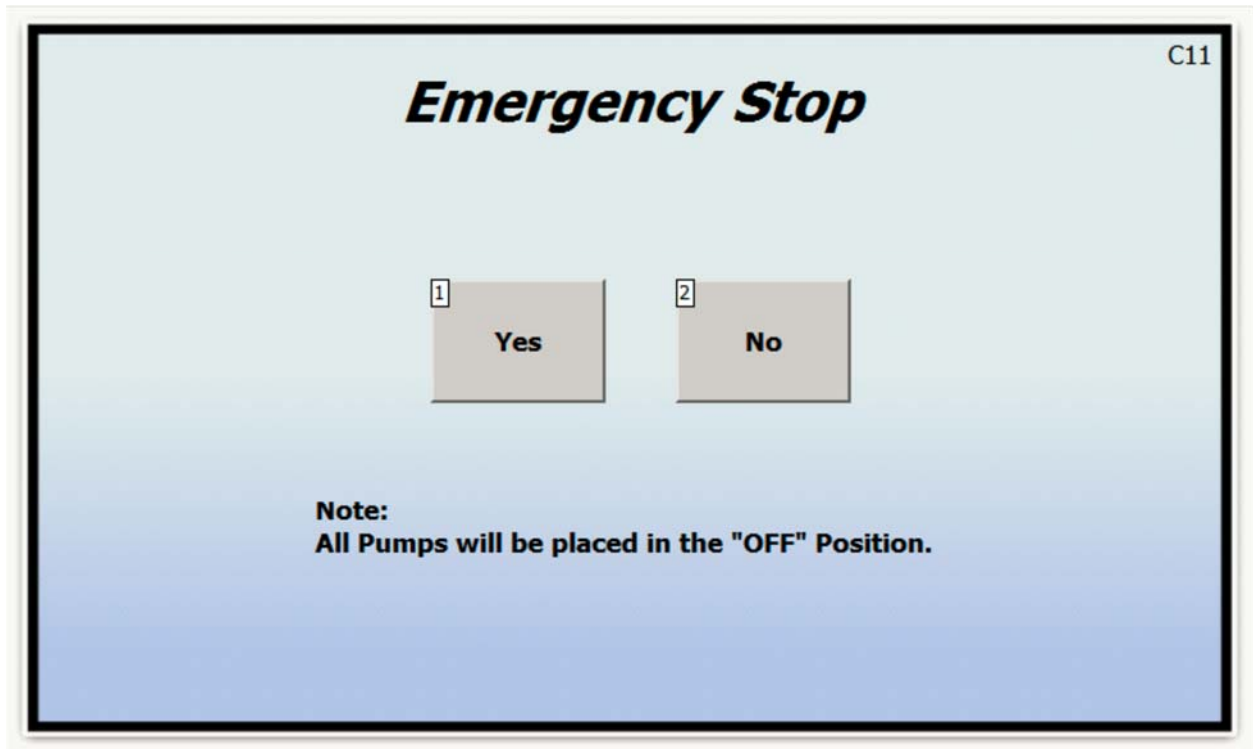

Emergency Stop Button – By pressing the red Mushroom Button on the home page will direct you to the emergency stop screen. If yes is pressed, all of the pump will be placed into the “Off” position. They will remain in that position until the user places the pumps into the “Auto” or “Hand” position.



Training – a list of short videos can be viewed under the Training Button

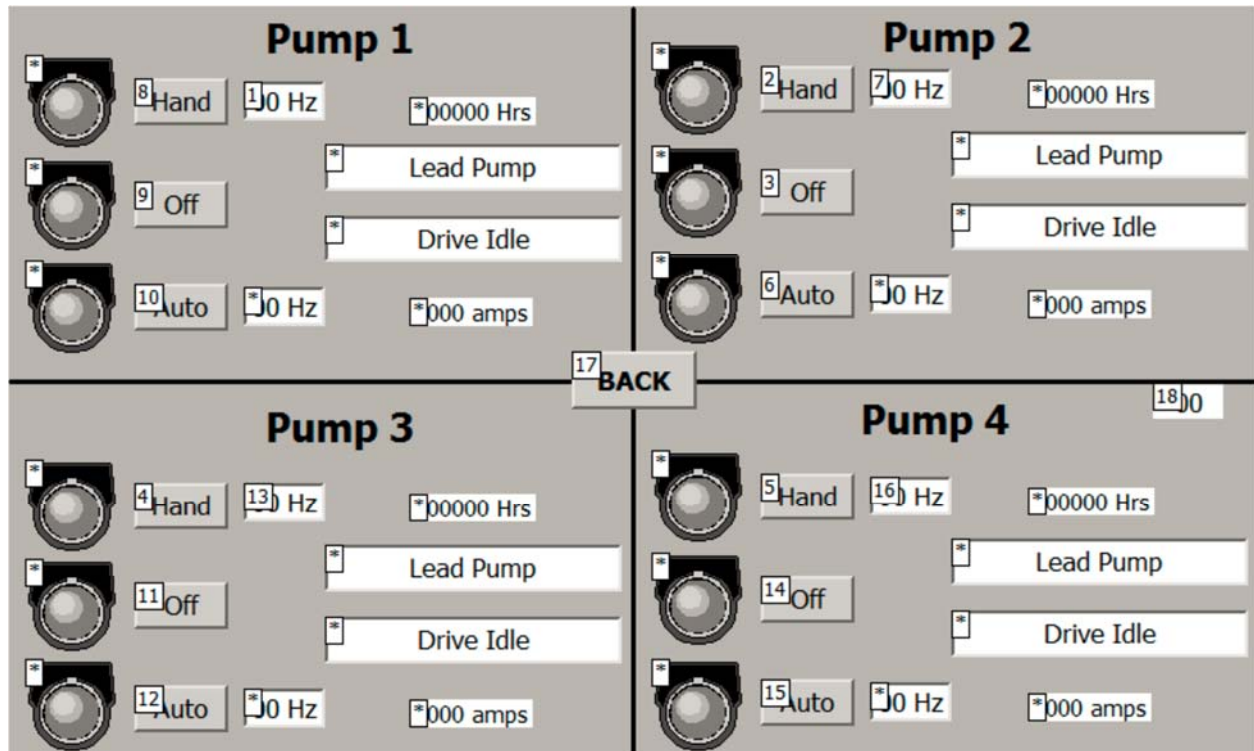

Hand – will place a pump in the hand position and will run continuously at the speed set by the operator.

Off – will place a pump in the off position and will not be in the pump sequence of operation.

Auto – will place a pump in the auto position and will maintain the system set-point.

Lead Drive Indicator – will show which pump is lead, lag1, lag2 or lag3 (if applicable).

Drive Idle – will show which pump is currently running or in the idle position.

Hours – will show the amount of hours the pumps has been running.

Amps – will show the current amp draw for each pump.

BOP Operations

USING PLC TO CONTROL DRIVE	
Steps	Result on the Display
Parameter (P700)	
1 -Press "P" in order to access the Parameter	r0000
2 -Press "Up Arrow" until P700 is displayed	P700
3 -Press "P" in order to reach the Parameter Value	1
4 -Press "Down Arrow" to obtain the required Value	5
5 -Press "P" to acknowledge the Value and to Save the Value	P700
Then	
Parameter (P1000)	
1 -Press "Up Arrow" until P1000 is displayed	P1000
2 -Press "P" in order to reach the Parameter Value	1
3 -Press "Down Arrow" to obtain the required Value	5
4 -Press "P" to acknowledge the Value and to Save the Value	P1000
5 -Press "Fn" to display	r0000
6 -Press "P" to display the Hertz	0.00
At this point, The Drive is being Controlled by Touchscreen.	

Press Up

USING BOP TO CONTROL DRIVE	
Steps	Result on the Display
Parameter (P700)	
1 -Press "P" in order to access the Parameter	r0000
2 Press "Up Arrow" until P700 is displayed	
3 -Press "P" in order to reach the Parameter Value	5
4 -Press "Down Arrow" to obtain the required Value	1
5 -Press "P" to acknowledge the Value and to Save the Value	P700
Then	
Parameter (P1000)	
1 -Press "Up Arrow" until P1000 is displayed	P1000
2 -Press "P" in order to reach the Parameter Value	5
3 -Press "Down Arrow" to obtain the required Value	1
4 -Press "P" to acknowledge the Value and to Save the Value	P1000
5 -Press "Fn" to display	r0000
6 -Press "P" to display the Hertz	0.00
<p>At this point Press the "Green Button" to Start Drive. Press the "Up Arrow" or "Down Arrow" until desired speed is Set. To turn OFF Drive, Press the "Red Button" the Drive will Ramp Down. NOTE: During this Mode, the Drive will Run at its Set Speed, it will NOT Regulate the Pressure.</p>	

3.2 Operator panels for MICROMASTER

MICROMASTER drive units can be optionally equipped with a BOP (Basic Operator Panel) or AOP (Advanced Operator Panel). The AOP distinguishes itself as a result of a plain text display which simplifies operator control, diagnostics as well as also commissioning (start-up).

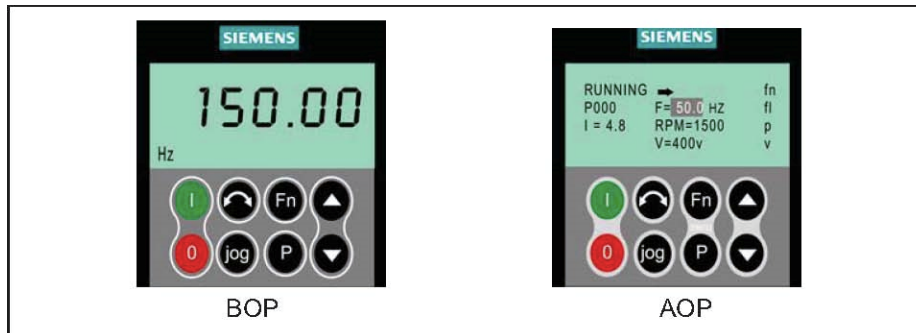

Fig. 3-14 Operator panels

3.2.1 Description of the BOP (Basic Operator Panel)

The BOP, available as option, allows drive inverter parameters to be accessed. In this case, the Status Display Panel (SDP) must be removed and the BOP either inserted or connected in the door of a cabinet using a special mounting kit (Operator panel door mounting set) (refer to the Attachment A).

Parameter values can be changed using the BOP. This allows the MICROMASTER drive unit to be set-up for a particular application. In addition to the keys (refer to Section 3.2.3), it includes a 5-digit LCD display on which the parameter numbers rxxxx and Pxxxx, parameter values, parameter units (e.g. [A], [V], [Hz], [s]), alarm Axxxx or fault messages Fxxxx as well as setpoints and actual values.

NOTE

- ⌚ Contrary to the AOP, for the BOP, parameters do not have to be set or taken into consideration when establishing the communications between the BOP and drive inverter.
- ⌚ A BOP does not have a local memory. This means that it is not possible to save a parameter set on the BOP.

3.2.2 Description of the AOP (Advanced Operator Panel)

An AOP (this is available as option) has the following additional functions with respect to a BOP:

- ⌚ Multi-language and multi-line plain text display
- ⌚ Units are additionally displayed, such as [Nm], [°C], etc.
- ⌚ Active parameters, fault messages, etc. are explained
- ⌚ Diagnostics menu to support troubleshooting
- ⌚ The main menu is directly called by simultaneously pressing keys Fn and P
- ⌚ Timer with 3 switching operations per entry
- ⌚ Up to 10 parameter sets can be downloaded / saved

⌚ Communications between an AOP and MICROMASTER are realized using the USS protocol. An AOP can be connected to the BOP link (RS 232) as well as to the COM link interface (RS 485) of the drive inverter.

⌚ Multi-point capable coupling to control (open-loop) and visualize up to 31 MICROMASTER drive inverters. The USS bus must, in this case, be configured and parameterized via the drive inverter terminals of the COM link interface. Please refer to Sections 3.2.3, 3.2.4 and the AOP Manual for additional details.











NOTE

⌚ Contrary to the BOP, for the AOP, the communications parameters of the particular interface must be taken into account.

⌚ When inserting / connecting to the drive inverter, the AOP automatically changes the parameter P2012 (USS-PZD length) to 4 corresponding to the interface.

COM link: P2012[0] BOP
link: P2012[1]

⌚ For DriveMonitor, the default value for the USS-PZD length is set to 2. This results in a conflict if the AOP and the DriveMonitor are operated, alternating, at the same interface. Remedy: Increase the USS-PZD length to 4.

Operator panel/key	Function	Effects
	Status display	The LCD indicates the settings which the drive inverter is presently using.
	Start motor	The drive inverter is started by pressing the key. This key is de-activated in the default setting. Parameter P0700 or P0719 should be changed as follows to activate the key: BOP: P0700 = 1 or P0719 = 10 ... 16 AOP: P0700 = 4 or P0719 = 40 46 on the BOP link P0700 = 5 or P0719 = 50 56 on the COM link
	Stop motor	OFF1 When this key is pressed, the motor comes to a standstill within the selected ramp-down time. It is de-activated in the default setting; to activate → refer to the "Start motor" key. OFF2 The motor coasts down to a standstill by pressing the key twice (or pressing once for a longer period of time). This function is always activated.
	Direction reversal	To reverse the direction of rotation of the motor, press this key. The opposing direction is displayed using the minus character (-) or by the flashing decimal point. In the default setting this function is de-activated; to activate it → refer to the "Start motor" key.
	Jog motor	In the "Ready to power-on" state, when this key is pressed, the motor starts and rotates with the pre-set jog frequency. The motor stops when the key is released. When the motor is rotating, this key has no effect.
	Functions	<p>This key can be used to display additional information. If you press the key during operation, independent of the particular parameter, for two seconds, then the following data is displayed:</p> <ol style="list-style-type: none"> 1. Voltage of the DC current link (designated by d – units V). 2. Output current (A) 3. Output frequency (Hz) 4. Output voltage (designated by o – units V). 5. The value, selected in P0005 (if P0005 is configured so that one of the above pieces of data is displayed (1 to 4), then the associated value is not re-displayed). <p>The displays mentioned above are run-through one after the other by pressing again.</p> <p>Step function Starting from any parameter (rXXXX or PXXXX), if the key Fn is briefly pressed, then a jump is immediately made to r0000. You can then, when required, change an additional parameter. After returning to r0000, when key Fn is pressed, then the system returns to the starting point.</p> <p>Acknowledgement If alarm and fault messages are present, then these can be acknowledged by pressing key Fn.</p>
	Parameter access	Parameters can be accessed by pressing this key.
	Increase value	When this key is pressed, the displayed value is increased.
	Reduce value	When this key is pressed, the displayed value is decreased.
	AOP menu	Calls the AOP menu prompting (this is only available for AOP).